

Making a typewriter with an old keyboard and a dot matrix printer. (interfacing with arduino)

This project shows how to recycle an old keyboard and a dot matrix printer to make a typewriter.

What and how.

The idea is connect the keyboard to the printer with a basic and cheap interface, i have used Arduino because is a fast development board for this kind of projects and have a large community behind. The board read the keyboard (use a data/clock system) and transform this info about the character to the printer. Parallel format controlling the strobe.

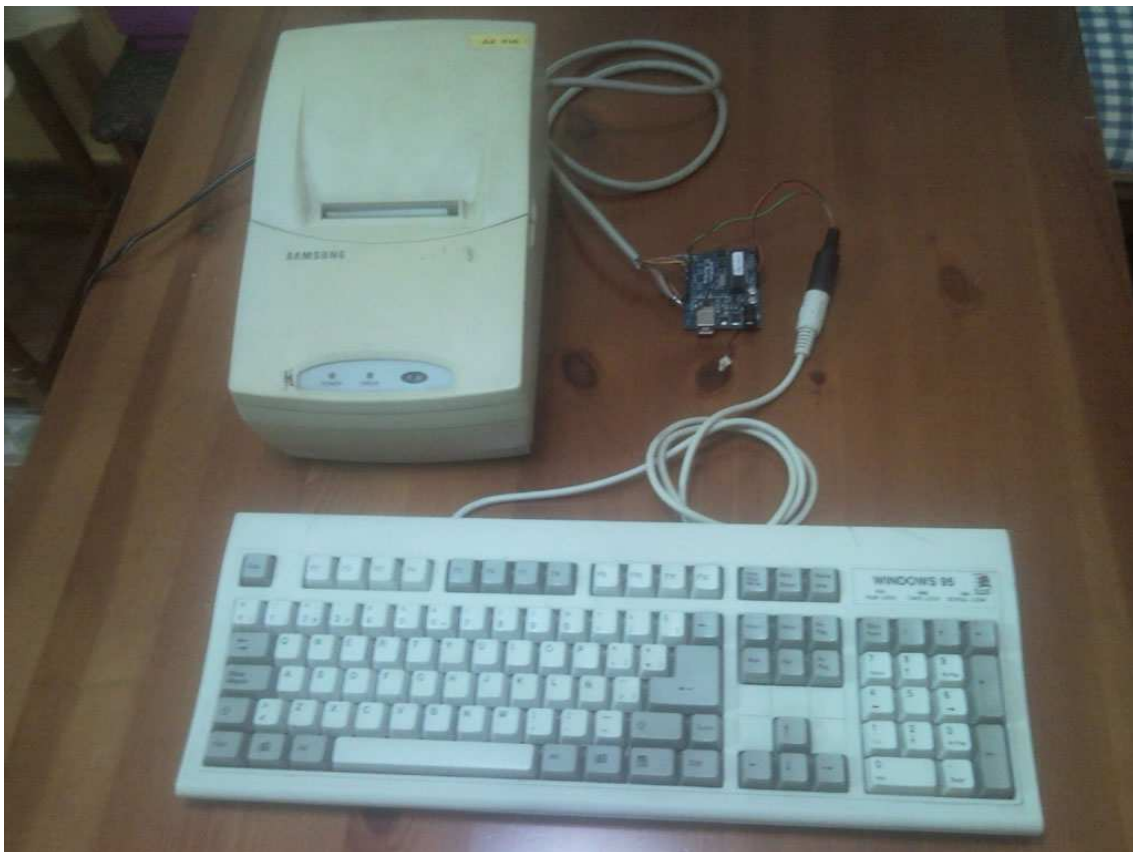

You can see the video here:

<http://www.youtube.com/watch?v=08t44T94SnE>

Hardware.

Is very basic too, a keyboard adapter with clock, data, power and GND (figure-1), a printer adapter with 8 data bits, strobe and GND (figure-2) all this

Connected to Arduino as this.

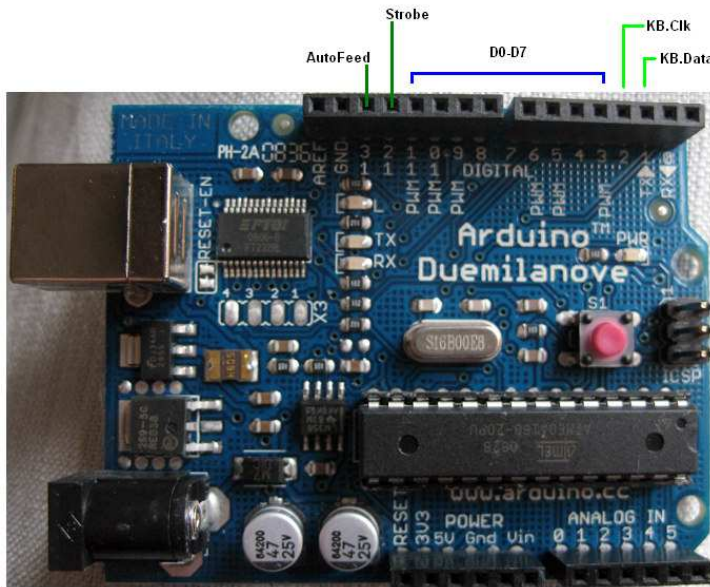

AT keyboard connector (DIN5)

Connector Pin #	Purpose
Pin 1	KBDCLK (clock)
Pin 2	KBDAT (data)
Pin 3	KBRST (reset, not used)
Pin 4	GND
Pin 5	VCC (+5V)

<http://www.bbdssoft.com/keyboard.html>

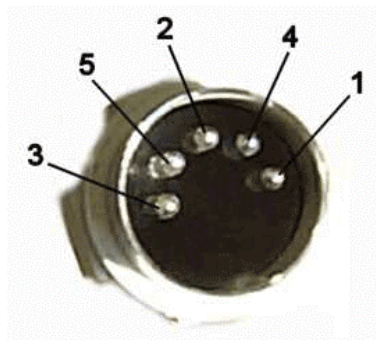

Figure-1

Centronics pinout

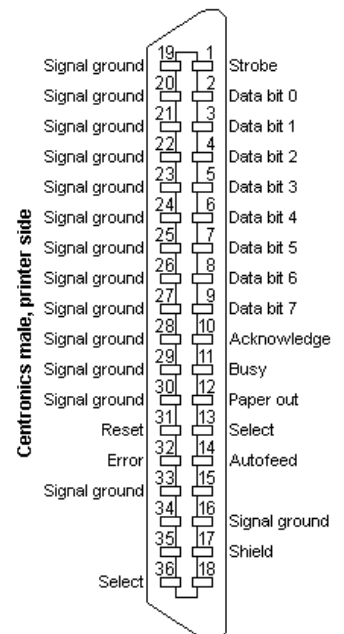

Figure-2

Software.

```
// Typewriter with an old AT Keyboard and a Dot Matrix printer.
// 2011 www.xbot.es
// Francisco Reinoso "furri"

#include <PS2Keyboard.h> // library to use a PS2Keyboard with Arduino
#include <string.h>
#include <stdio.h>

#define KBD_CLK_PIN 3
#define KBD_DATA_PIN 2
#define d0 4
#define d1 5
#define d2 6
#define d3 7
#define d4 8
#define d5 9
#define d6 10
#define d7 11
#define strobe 12
#define autofd 13

PS2Keyboard keyboard;

int character = 0;

void setup() {
  keyboard.begin(KBD_DATA_PIN);
  pinMode(d0, OUTPUT);
  pinMode(d1, OUTPUT);
  pinMode(d2, OUTPUT);
  pinMode(d3, OUTPUT);
  pinMode(d4, OUTPUT);
  pinMode(d5, OUTPUT);
  pinMode(d6, OUTPUT);
  pinMode(d7, OUTPUT);
  pinMode(strobe, OUTPUT);
  pinMode(autofd, OUTPUT);
  digitalWrite(autofd,HIGH);
  digitalWrite(strobe,HIGH);
  Serial.begin(9600);
  delay(1000);
}

#define is_printable(c) (!(c&0x80)) // don't print if top bit is set

void imprime(int letra)
{
  // decode character into 8 bits
  if (letra >= 128) { letra = letra - 128; digitalWrite(d0,HIGH); } else { digitalWrite(d0,LOW); }
  if (letra >= 64) { letra = letra - 64; digitalWrite(d1,HIGH); } else { digitalWrite(d1,LOW); }
  if (letra >= 32) { letra = letra - 32; digitalWrite(d2,HIGH); } else { digitalWrite(d2,LOW); }
  if (letra >= 16) { letra = letra - 16; digitalWrite(d3,HIGH); } else { digitalWrite(d3,LOW); }
  if (letra >= 8) { letra = letra - 8; digitalWrite(d4,HIGH); } else { digitalWrite(d4,LOW); }
  if (letra >= 4) { letra = letra - 4; digitalWrite(d5,HIGH); } else { digitalWrite(d5,LOW); }
  if (letra >= 2) { letra = letra - 2; digitalWrite(d6,HIGH); } else { digitalWrite(d6,LOW); }
  if (letra >= 1) { digitalWrite(d7,HIGH); } else { digitalWrite(d7,LOW); }
  // send the character to the printer
  digitalWrite(strobe,LOW);
  delayMicroseconds(2);
  digitalWrite(strobe,HIGH);
}

void loop() {
  if(keyboard.available()) {
    byte c = keyboard.read();
    if ( c == 13 ) { Serial.print(c); imprime(10); }
    else
    {
      if ( is_printable(c) ) { Serial.print(c); imprime(c); } // don't print special characters
    }
  }
}
```